

Glasdon **VISAGE™ SCREEN SYSTEM - FOUR SIDED (FLAT PACK)**
OPERATIONAL, ASSEMBLY & FIXING INSTRUCTION LEAFLET

NOTE: Ensure that all relevant personnel read the points listed below and that a copy is passed on to staff involved with the installation. Please also refer to the 'Manual Handling Operations Regulations 1992' during the handling of the product and materials used for installation. The total weight of this product is 80kg (770L) and 92kg (1280L).

OPENING AND CLOSING FOUR SIDED SCREEN COMPLETE WITH DOOR:

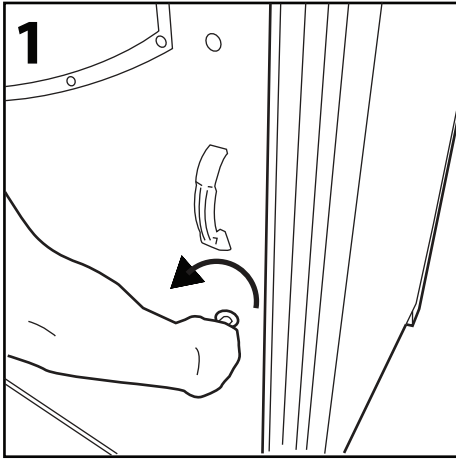

1
 Insert Glasdon Key into lock and turn anticlockwise to unlock the door. (Alternatively: Turn twist lock anticlockwise to unlock door.)

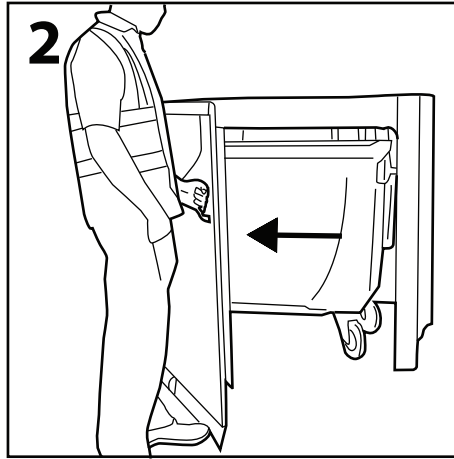

2
 Using handle pull door open to 90 degree position.

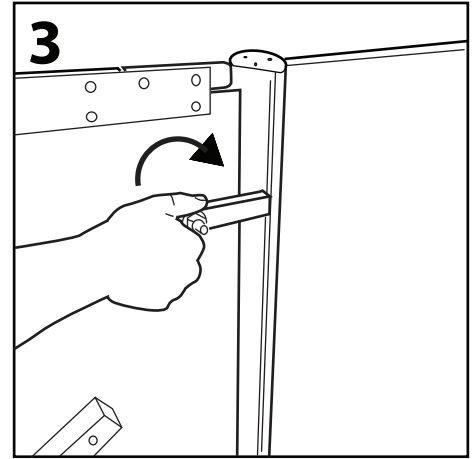

3
 To ensure that the door remains open whilst removing the wheeled bin, turn the door stay catch clockwise so that it is positioned horizontally.

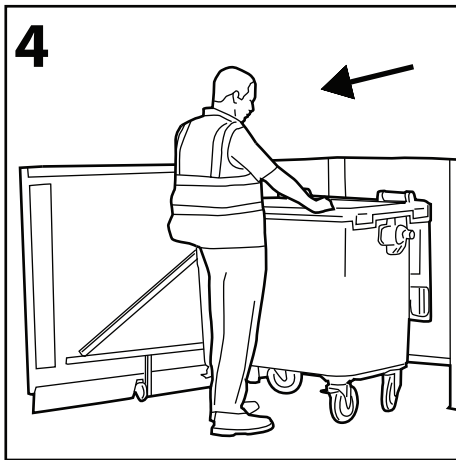

4
 Remove wheeled bin.

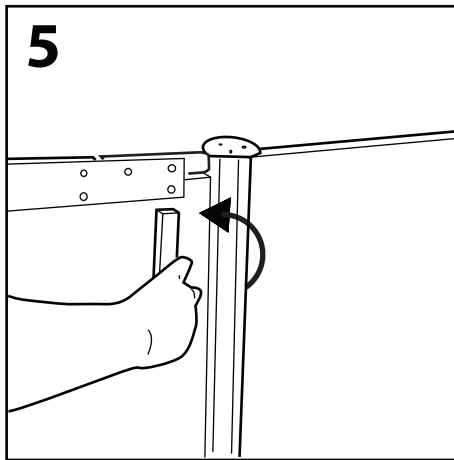

5
 After replacing the wheeled bin, remove the door stay catch by pushing upwards anticlockwise so that it is positioned vertically.

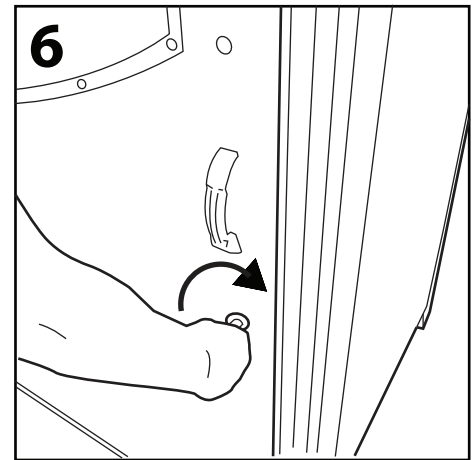

6
 Close the door and insert key into lock. Turn key clockwise to lock door. (Alternatively: Turn twist lock clockwise to lock door.)

NOTE: To allow the wheeled bin to sit inside the screen in the correct position, it is recommended that the lid of the wheeled bin remains attached and is simply folded over the back of the bin when in use. For best results please ensure that the front of the wheeled bin is level with the front two extrusions.

Glasdon AND **MODUS™** ARE TRADEMARKS OF GLASDON GROUP AND ITS SUBSIDIARIES IN THE U.K. AND OTHER COUNTRIES.

Replacement components are available direct from GLASDON. Glasdon U.K. Ltd reserves the right to alter specifications without prior notice. GLASDON cannot be held responsible for claims arising from incorrect installation, unauthorised modifications or misuse of the product.

Issue 2 December 2011 C000/0407
 © Copyright 2011

Glasdon

Preston New Road
 BLACKPOOL
 Lancashire FY4 4UL
 Tel: 01253 600410
 Fax: 01253 792558
 E-mail: sales@glasdon-uk.co.uk
 Web: www.glasdon.com

We recommend that a risk assessment is undertaken to identify an appropriate location for your waste collection and recycling units. In order to reduce risk, some organisations decide to place the units a **minimum of 5 metres** away from buildings. Any potential risk can be further reduced by maintaining a regime of regularly emptying the unit.

TOOLS REQUIRED:

13mm Spanner	x1	17mm Spanner	x2
Hand Drill with Pozi Drill Bit	x1	6mm Allen Key	x1
10mm x 150mm Masonry Drill Bit	x1		
Rubber Mallet	x1		
Hammer	x1		

KIT CONTENTS:

		770L	1280L
ITEM A	Side Panel	x1	x1
ITEM B	Back Panel	x1	x1
ITEM C	Side Panel	x1	x1
ITEM D	Door Panel	x1	x1
ITEM E	5mm x 20mm Chipboard Screw	x37	x41
ITEM F	M10 x 60mm Ground Fixing Bolt	x6	x6
ITEM G	Support Leg	x2	x2
ITEM H	Side Skirting (optional)	x2	x2
ITEM I	Back Skirting (optional)	x1	x1
ITEM J	Repair Washer M5 x 25mm S/S (optional)	x16	x20

NOTE: Some fixings apply to the optional skirting so there may be less fixings than stated.

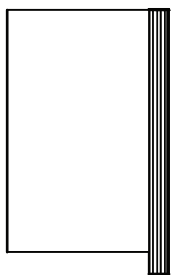
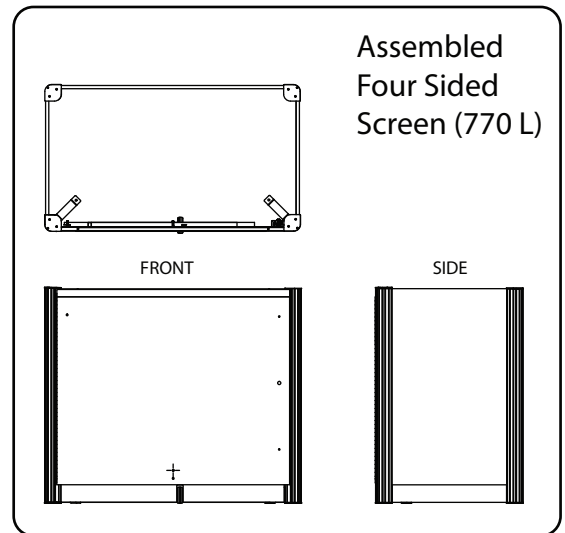

A

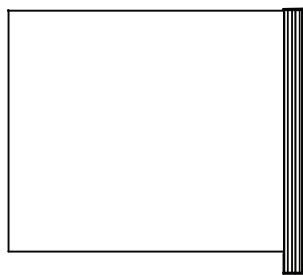

B



C

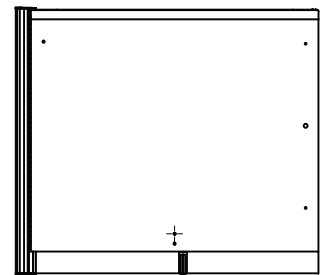

D



E

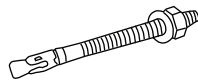

F



G

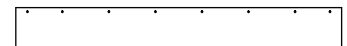

H



J

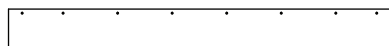

I

Step 1: Assembly of Four Sided Screen

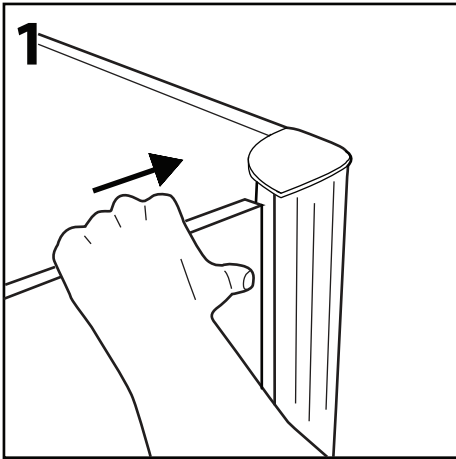

Hold panel (B) up to the extrusion on panel (A) ensuring that the feet with the pre-drilled holes are on the ground. Push the end of the board into the extrusion slot.

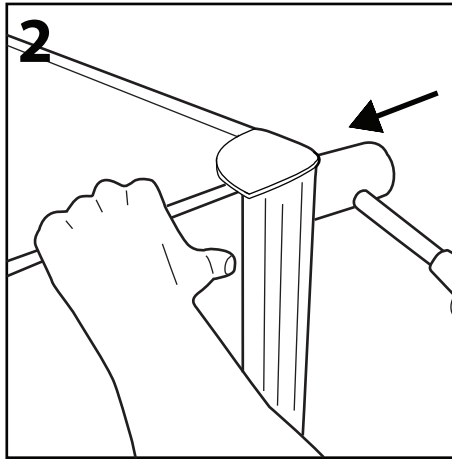

Using rubber mallet (so not to damage the extrusions) tap the side at the top of the extrusion so that the board is pushed firmly into the extrusion without any gaps.

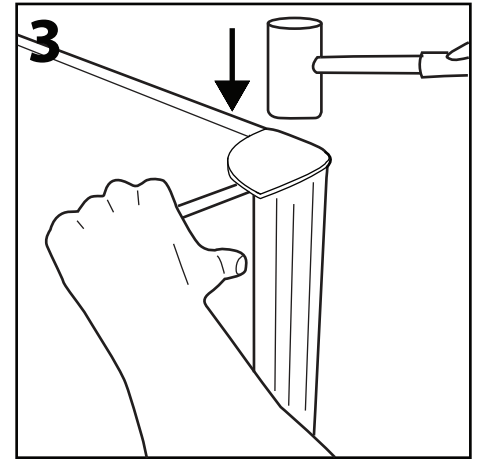

Tap the top of the extrusion to ensure the board is level up to the top of the extrusion cover cap.

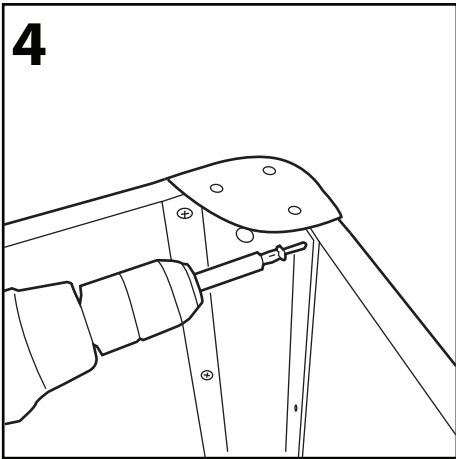

Using hand drill and screw provided (E), secure the top fixing in position by screwing from the inside of the extrusion into the board.

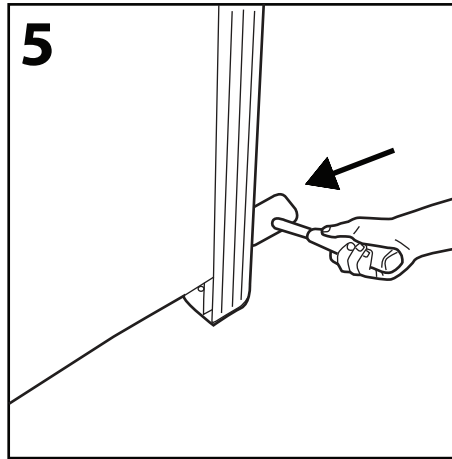

Using rubber mallet, tap the side at the bottom of the extrusion to ensure that the board is pushed firmly into the extrusion without any gaps.

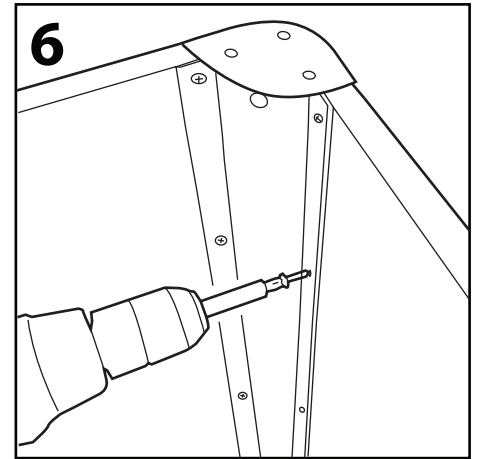

Using hand drill and 6 off screws provided (E), secure the remaining fixings on the inside of the extrusion by screwing through the extrusion into the board.

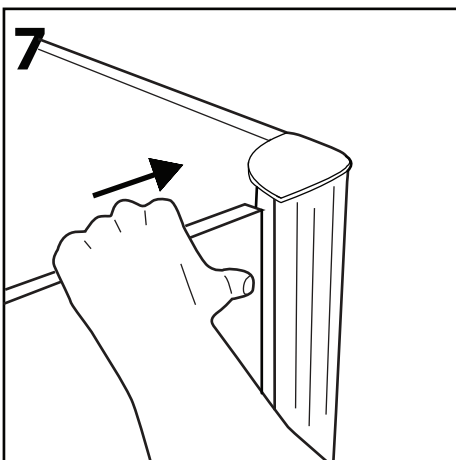

With two panels assembled offer panel (C) up to the extrusion on panel (B) ensuring that the feet with the pre-drilled holes are on the ground. Push the end of the board into the extrusion slot.

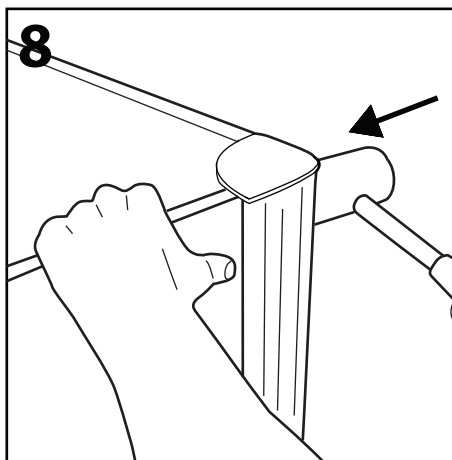

Using rubber mallet, tap the side at the top of the extrusion so that the board is pushed firmly into the extrusion without any gaps.

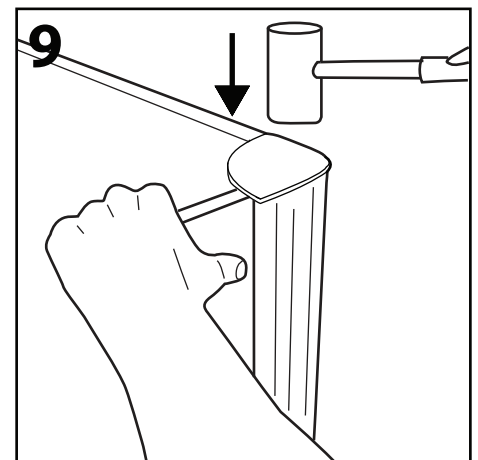

Tap the top of the extrusion to ensure the board is level up to the top of the extrusion cover cap.

Step 1: Assembly of Four Sided Screen (continued)

10

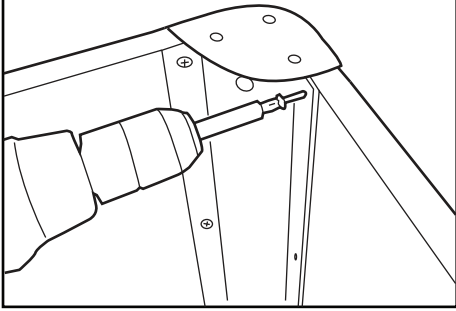

Using hand drill and screw provided (E), secure the top fixing in position by screwing from the inside of the extrusion into the board.

11

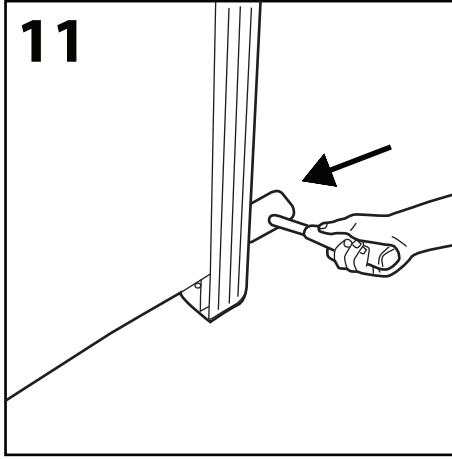

Using rubber mallet, tap the side at the bottom of the extrusion to ensure that the board is pushed firmly into the extrusion without any gaps.

12

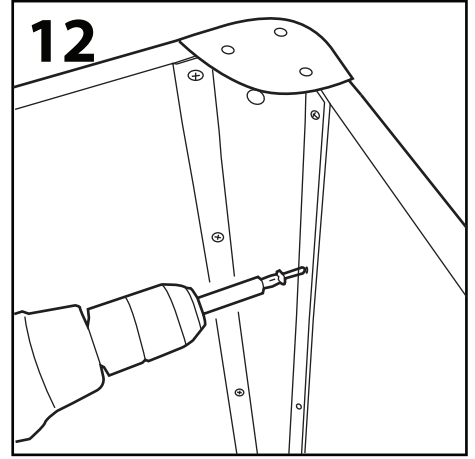

Using hand drill and 6 off screws provided (E), secure the remaining fixings on the inside of the extrusion by screwing through the extrusion into the board.

13

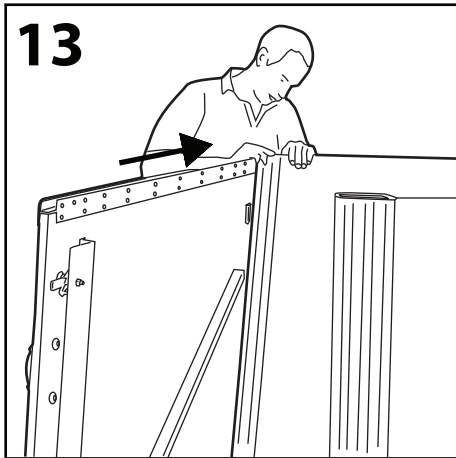

With three panels assembled offer the door panel extrusion (D) up to the end of panel (A). Push the end of the board into the extrusion slot.

14

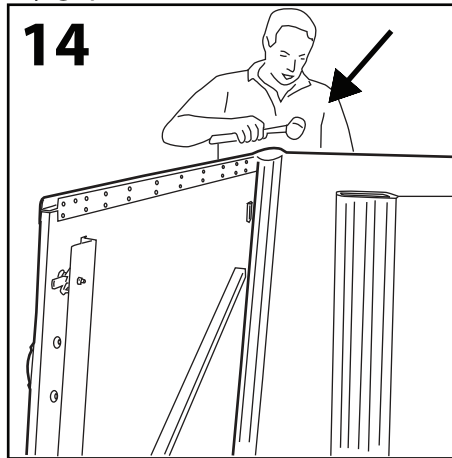

Using rubber mallet, tap the side at the top of the extrusion so that the board is pushed firmly into the extrusion without any gaps. Tap the top of the extrusion to ensure the board is level up to the top of the extrusion cap.

15

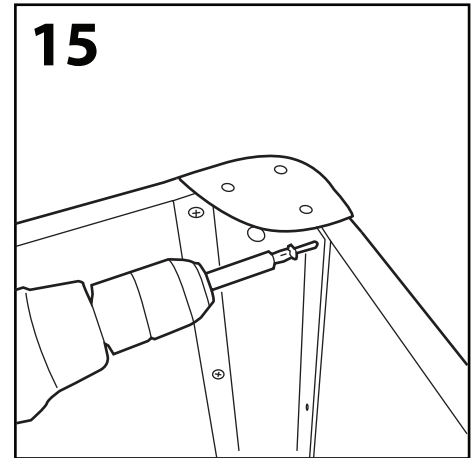

Using hand drill and screw provided (E), secure the top fixing in position by screwing from the inside of the extrusion into the board.

16

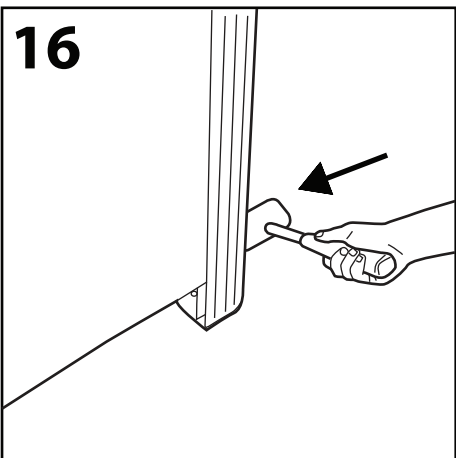

Using rubber mallet, tap the side at the bottom of the extrusion to ensure that the board is pushed firmly into the extrusion without any gaps.

17

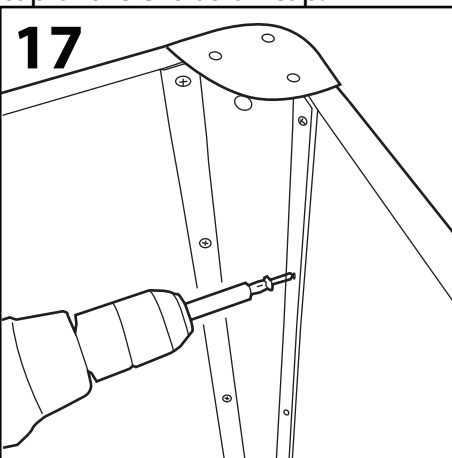

Using hand drill and 6 off screws provided (E), secure the remaining fixings on the inside of the extrusion screwing through the extrusion into the board.

18

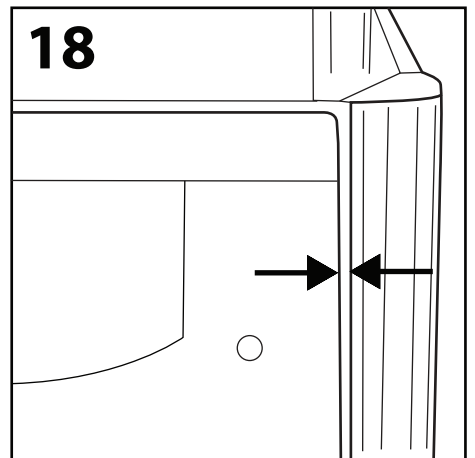

Move the door to the closed/locked position (see operator instructions p1). Align the edge of the door with the extrusion so that there is an even gap running all the way down. (approximately 10mm wide).

Step 2: Adjustment of Spigot Legs When Sited on Uneven Ground

(If not required move on to Step 3)

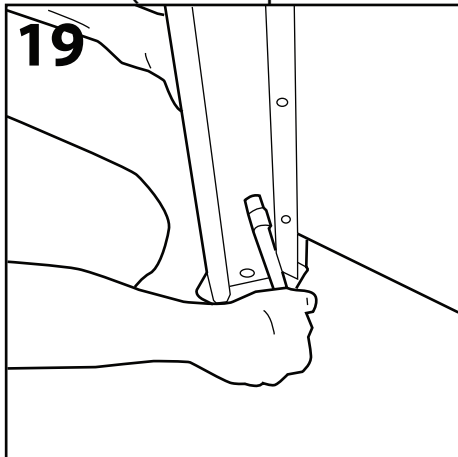

Using a 13mm spanner/socket unscrew the two bolts with washers on the inside at the bottom of the extrusions and remove.

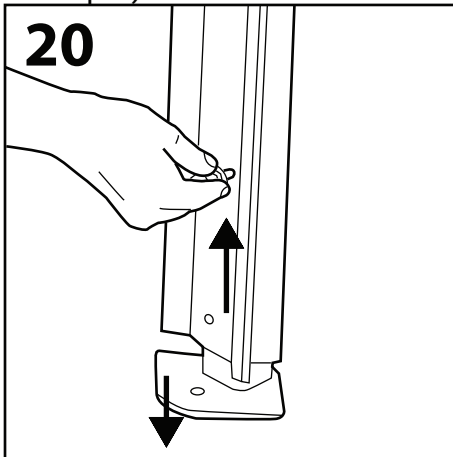

Lift the extrusion upwards and pull the spigot leg down to a more appropriate height ensuring that the screen is now level.

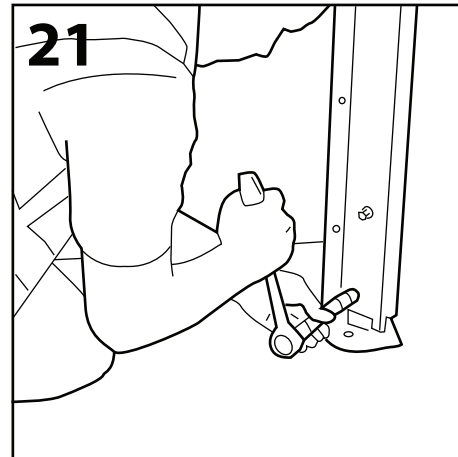

Replace the bolts and washers into the new holes within the spigot leg and tighten with spanner/socket. Repeat Figs 19-21 on the other legs that need adjusting.

Step 3: Ground Fixing (Concrete In)

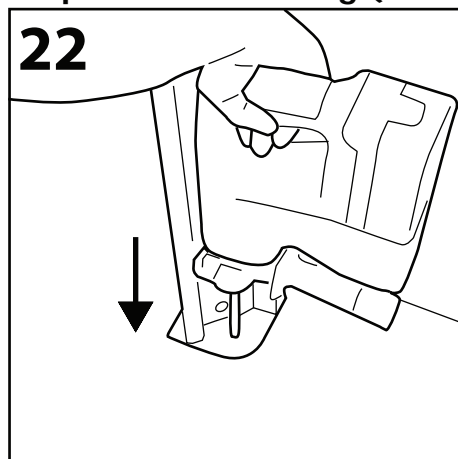

Using a 10mm masonry drill bit, drill through the hole in the spigot leg down into the concrete approx. 150mm deep.

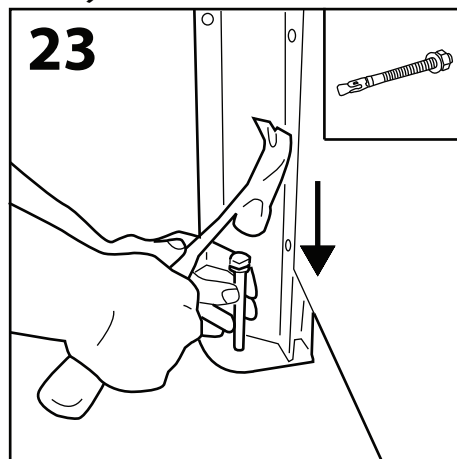

The fixing bolts (F) MUST appear as above with the nut and washer at the top of the bolt. Using a hammer, tap fixing bolt through the hole in the spigot leg until it is flush with the spigot plate.

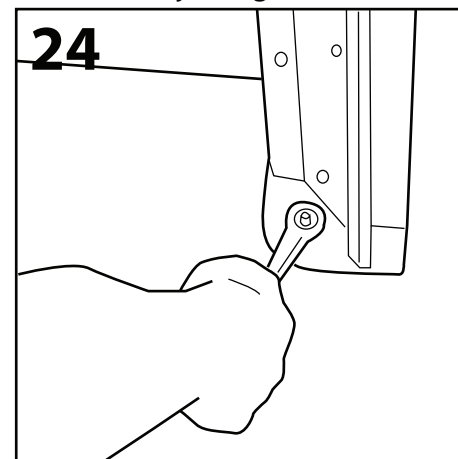

Tighten bolt using a spanner. Repeat Figs 22 - 24 to ground fix the other two extrusions.

Step 4: Attaching and Ground Fixing Compulsory Support Legs

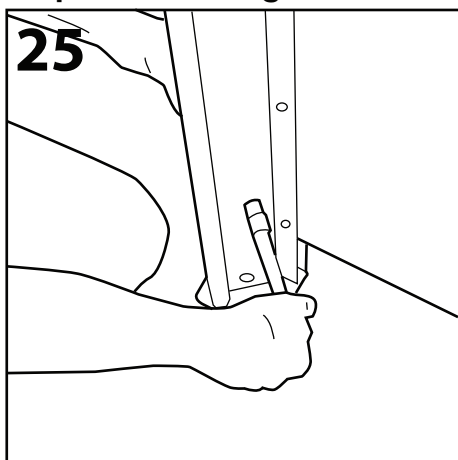

Using a 13mm spanner/socket unscrew the two bolts with washers at the bottom of the outermost extrusions and remove. (see diagram above showing location of support legs) If the spigot legs have been adjusted (Step 2) the panels will need to remain lifted in position so that the support legs go into the correct holes (may require two people).

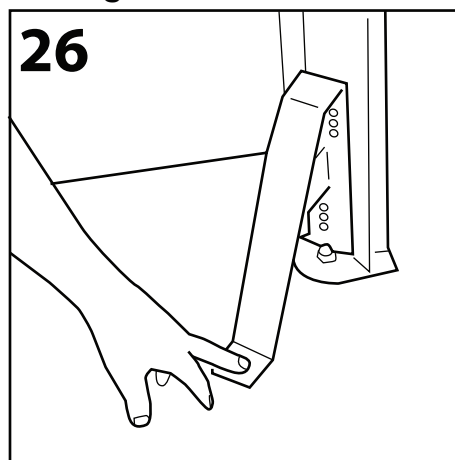
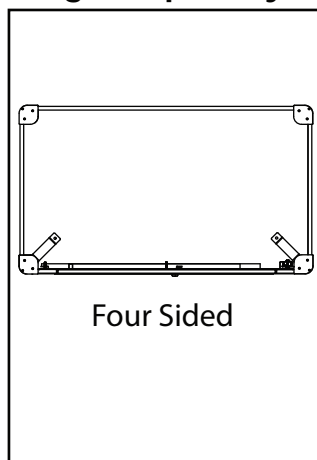

Place the support leg (G) up against the inside of the extrusion so that the leg protrudes outwards and stands on the ground. If the spigot legs have been adjusted there are several pre-drilled holes in the support leg to accommodate this adjustment.

Step 4: Attaching and Ground Fixing Compulsory Support Legs (continued)

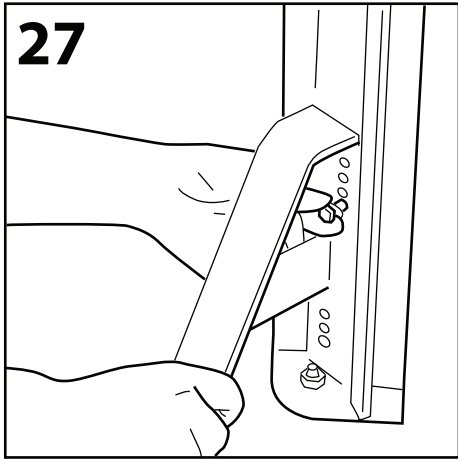

Replace the bolts and washers into the new holes through the support leg, extrusion and into the spigot leg. Tighten with 13mm spanner/socket.

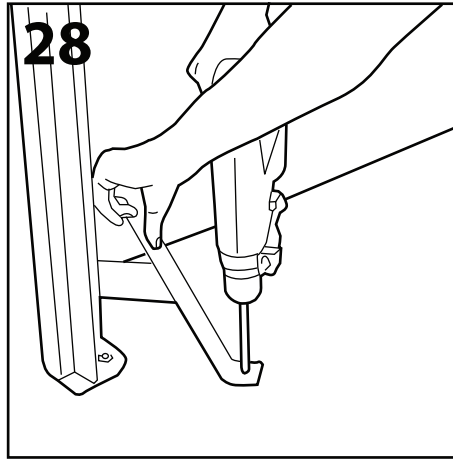

Ground fix the support legs into the ground as per Figs 22 - 24 (Step 3).

Step 5: Adjustment of Door Wheel (If Required)

IMPORTANT NOTE: The door wheel must be positioned so that it is touching the ground when the door is CLOSED. The main purpose of the door wheel is to support the large door when in the closed position.

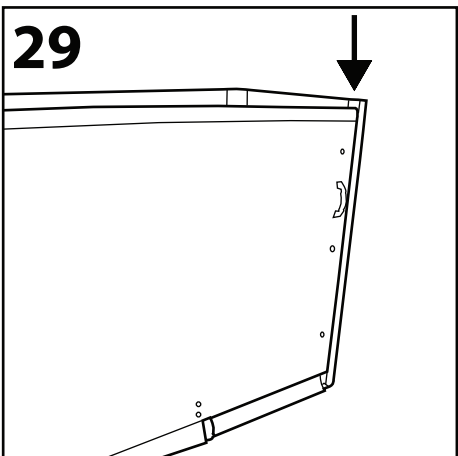

If the door is not level, as seen above, the door wheel can be adjusted.

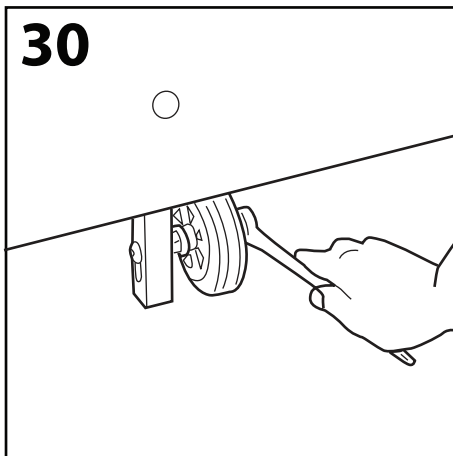

Using 17mm spanner, loosen nyloc nut on right hand side of wheel.

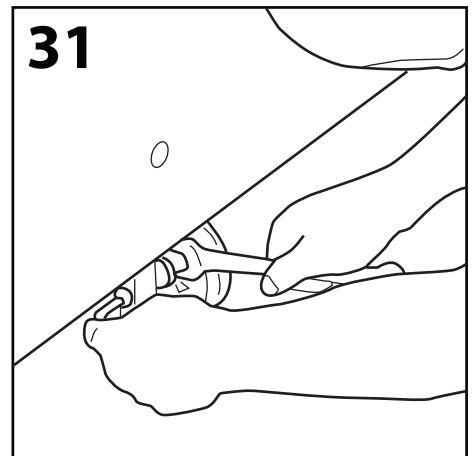

Using 17mm spanner and 6mm allen key, loosen nut on left side of the wheel to free the axle from the wheel support bar.

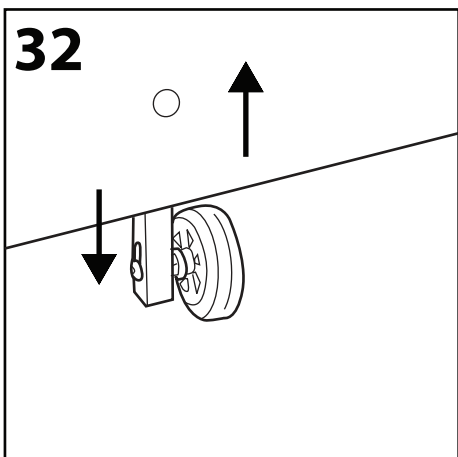

Lift door panel and pull wheel down so that the axle drops down the slot in the wheel support bar (may require two people).

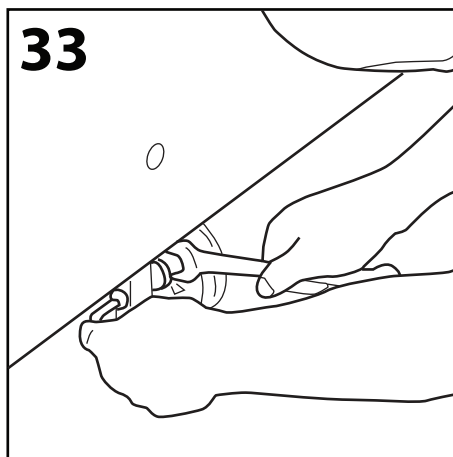

Once in correct position, tighten up nut (left of wheel) to lock the axle in place.

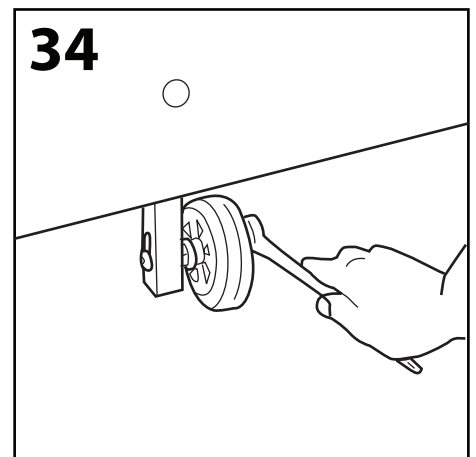

Tighten up nyloc nut (right of wheel) ensuring that wheel can still rotate freely but is secure on the axle.

Step 6: Further Adjustment of Door Wheel (If Required)

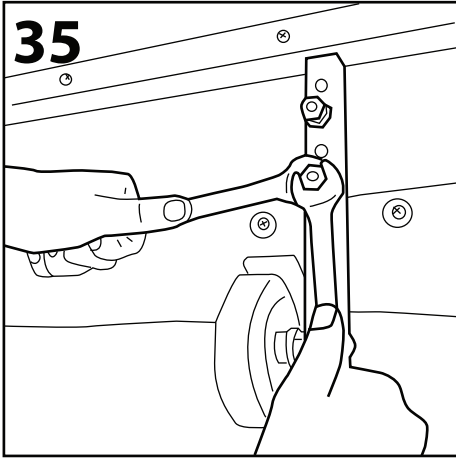

35
Using 17mm spanner, hold the nut closest to the wheel support bar and using a second spanner unscrew the outermost nut and remove. Repeat on other wheel support bar fixing point.

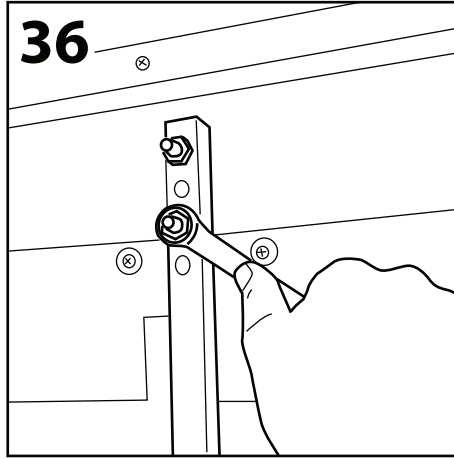

36
Using 17mm spanner remove the second nut and washer. Repeat on other wheel support bar fixing point.

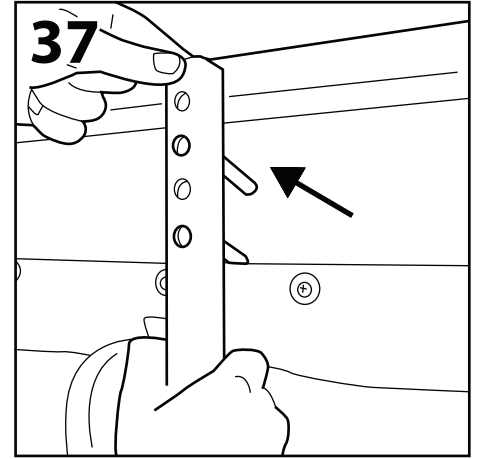

37
Lift the wheel support bar off the bolts, ensuring that the door is still supported.

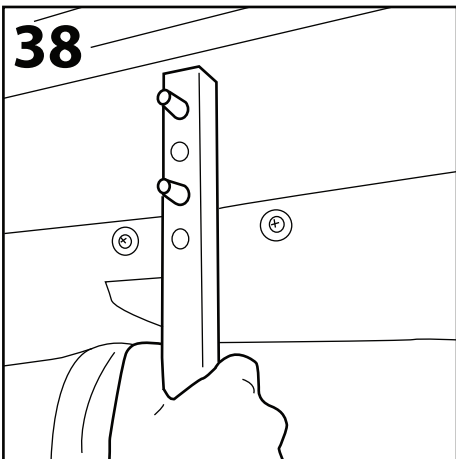

38
Replace the wheel support bar over the bolts using the alternative holes to make the adjustment of the door height.

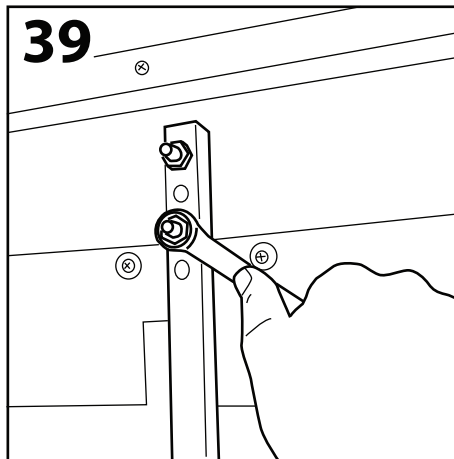

39
Making sure that the wheel support bar is 90 degrees to the door, replace the washer and first nut onto the bolt and tighten (do NOT overtighten).

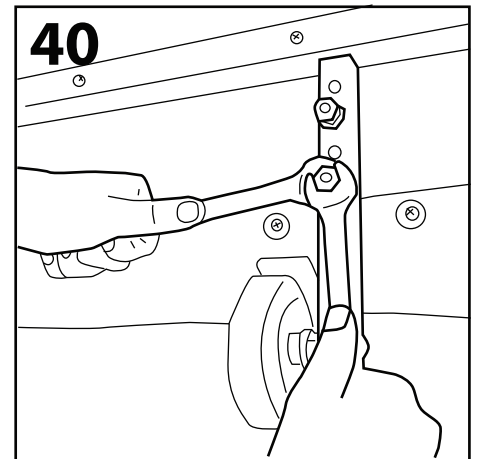

40
Holding the nut with the 17mm spanner, place the second nut over the bolt and tighten securely with a second spanner. Repeat figs 39 and 40 using other fixings. (Step 5 may need repeating)

Step 7: Attaching Rubber Skirting (Optional)

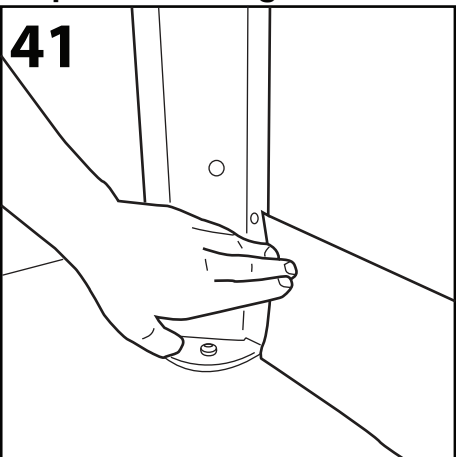

41
Using side skirting (H), on the INSIDE of the screen, align the end of rubber next to the extrusion so that it is touching the ground.

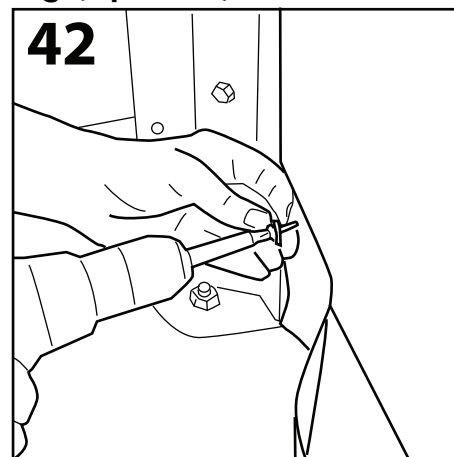

42
Using a screw (E) and washer (J), screw the fixing through the pre-drilled hole in the skirting through into the board.

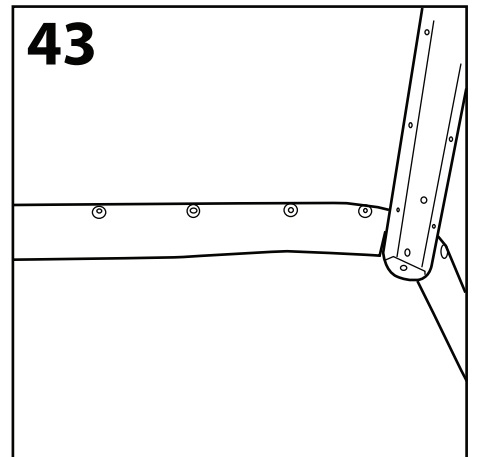

43
Repeat Fig 42 using the other fixings along the skirting ensuring to pull the rubber tight inbetween each point. Repeat Figs 41 - 43 using side skirting (H) and back skirting (I).